

moVa

CONTEMPORARY POOLS

10' x 20'-CP

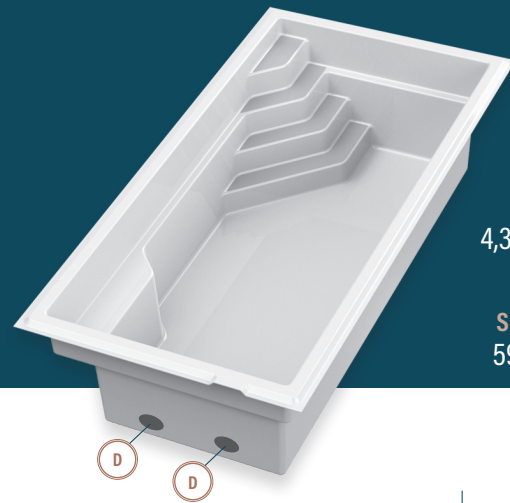

CAPACITY
4,302 US gallons
16,285 litres

SHELL WEIGHT
591 kg | 1,300 lb

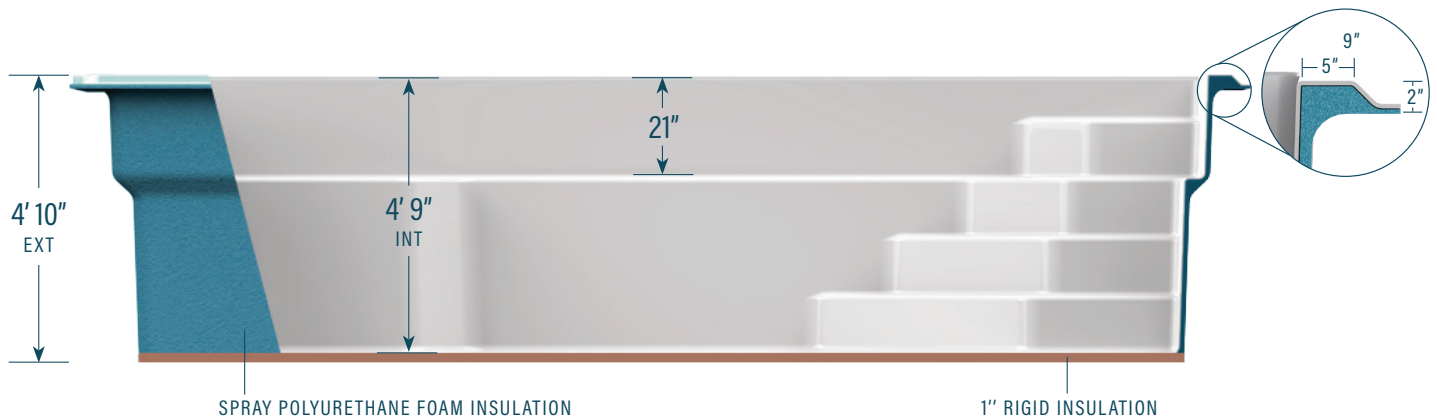
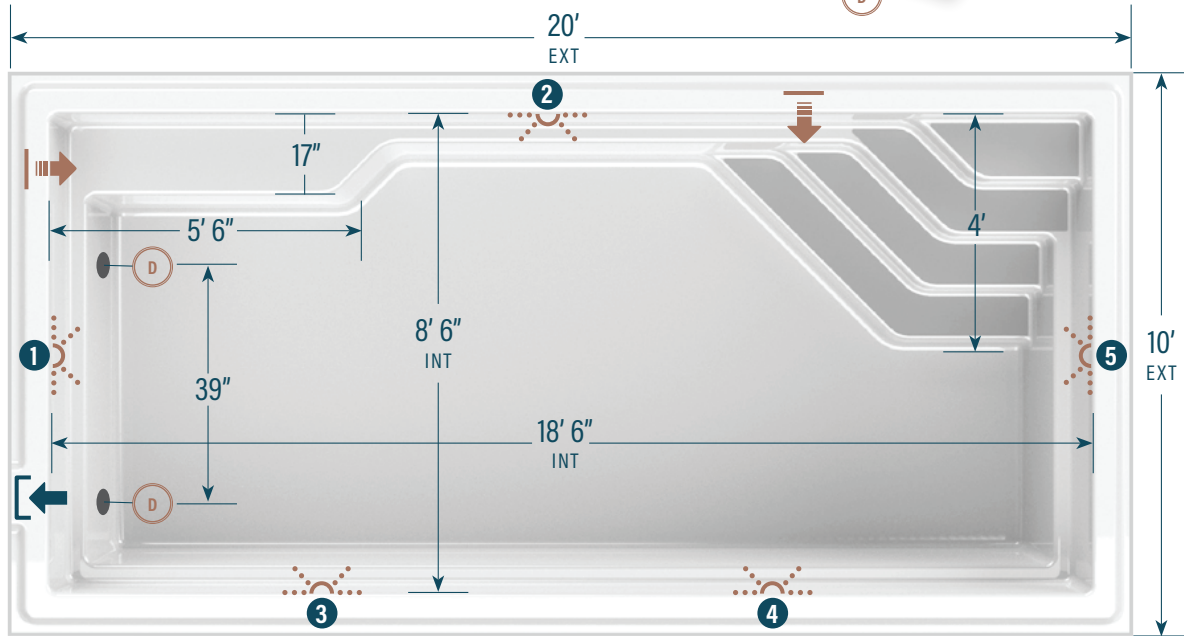

LEGEND

SKIMMER	→]	SIDE BOTTOM DRAIN	(D)	WATER RETURN	←]	LED LIGHT	⋯	COLORS	
								WILD WOLF	■
								SEA FOAM	■

LED LIGHT OPTION (Circle the desired LED lights)	①	②	③	④	⑤
--	---	---	---	---	---



The information in this document is provided for informational purposes only. Consult an authorized dealer and the Mova Pools installation guide for product specifications and installation instructions before purchasing a pool. An installation that does not conform to the instructions may void your warranty.

*Not a resident of Quebec or the Ottawa area? This model is available at a retailer near you.

MOVAPOOOLS.COM